



**TRUE FOOD SERVICE EQUIPMENT, INC.**

2001 East Terra Lane • P.O. Box 970 • O'Fallon, Missouri 63366  
 (636)240-2400 • Fax (636)272-2408 • (800)325-6152 • Intl Fax# (001)636-272-7546  
 Parts Dept. (800)424-TRUE • Parts Dept. Fax# (636)272-9471 • www.truemfg.com

Project Name: \_\_\_\_\_

A/A #

Location: \_\_\_\_\_

Item #: \_\_\_\_\_ Qty: \_\_\_\_\_

S/S #

Model #: \_\_\_\_\_

Model:  
**TCGG-48-S**

**Display Case:**  
*Stainless Steel Curved Glass Deli Case*



**TCGG-48-S**

- ▶ True's curved glass deli display case combines efficient, high volume merchandising and exceptional refrigeration with an elegant curved glass front for sophisticated presentation of deli products.
- ▶ High humidity gravity coil refrigeration system maintains 38°F to 40°F (3.3°C to 4.4°C) for the freshest display of meats, cheeses and deli products.
- ▶ Self-contained, environmentally friendly (CFC free) 134A refrigeration system.
- ▶ Cabinet is NSF-7 certified to hold open food product.
- ▶ Insulated double pane glass provides maximum insulation value for greater efficiency and energy savings. Both panes are tempered for safety.
- ▶ Two (2) adjustable, lighted, cantilevered PVC coated shelves.
- ▶ Fluorescent lamps are low UV emitting to enhance product appearance and increase shelf life.
- ▶ All stainless steel interior and exterior.

**ROUGH-IN DATA**

Specifications subject to change without notice.  
 Chart dimensions rounded up to the nearest 1/8" (millimeters rounded up to next whole number).

Model	Doors	Capacity (Cu. Ft.) (liters)	Shelves	Cabinet Dimensions (inches) (mm)			HP	Voltage	Amps	NEMA Config.	Cord Length (total ft.) (total m)	Crated Weight (lbs.) (kg)
				L	D <sup>†</sup>	H						
TCGG-48-S	2	23.5 666	2	48 <sup>1</sup> / <sub>4</sub> 1226	35 <sup>1</sup> / <sub>4</sub> 896	47 <sup>3</sup> / <sub>4</sub> 1213	1/3	115/60/1	11.8	5-15P	9 2.74	505 230

† Depth does not include 7/8" (23 mm) for rear door handle.

1/08 Printed in U.S.A.

**APPROVALS:**

**AVAILABLE AT:**

Model:  
**TCGG-48-S**

**Display Case:**  
*Stainless Steel Curved Glass Deli Case*



**STANDARD FEATURES**

**DESIGN**

- True's curved glass deli display case combines efficient, high volume merchandising and exceptional refrigeration with an elegant curved glass front for sophisticated presentation of deli products.
- Gravity coil refrigeration system guarantees the freshest display of meats, cheeses and deli products.

**REFRIGERATION SYSTEM**

- Factory engineered self-contained, capillary tube system using environmentally friendly (CFC free) 134A refrigerant.
- Extra large evaporator coil balanced with higher horsepower compressor and large condenser maintains 38°F to 40°F (3.3°C to 4.4°C).
- High humidity gravity coil refrigeration system. Ideally suited for deli meats, cheeses and salads.
- Condensing unit located behind panel in back of unit. Entire system slides out for easy cleaning and maintenance.
- Automatic defrost system; time-initiated, time-terminated.

**CABINET CONSTRUCTION**

- Exterior - all stainless steel front, sides, back and top.
- Interior - all stainless steel sides and 300 series stainless steel floor with coved corners.
- Insulation - entire cabinet structure is foamed-in-place using high density, CFC free, polyurethane insulation.
- Welded, heavy duty galvanized frame rail dipped in rust inhibiting enamel paint for corrosion protection inside and out.

- Frame rail fitted with leg levelers.

**CURVED FRONT DISPLAY GLASS**

- Insulated double pane glass provides maximum insulation value for greater efficiency and energy savings. Both panes are tempered for safety.

**DOORS**

- "Low-E", double pane thermal glass insert with mitered plastic channel frame.
- Each door fitted with 12" (305 mm) long molded plastic handle.
- Self-closing doors with smooth, even, positive closure. Sliding doors ride on stainless steel V-Channel with stainless steel bearings. Doors fit within plastic channel frame.

**SHELVING**

- Two (2) adjustable, lighted, heavy duty PVC coated wire shelves 42<sup>7</sup>/<sub>8</sub>" L x 22<sup>5</sup>/<sub>32</sub>" D (1090 mm x 563 mm) with light. Shelving system is cantilevered and angle can be adjusted to maximize presentation.

**LIGHTING**

- Case is equipped with 2 light sources for maximum product display; (1) shelf mounted and (1) cabinet mounted. Fluorescent lamps are low UV emitting to enhance product appearance and increase shelf life.

**MODEL FEATURES**

- Evaporator is epoxy coated to eliminate the potential of corrosion.
- Four (4) amp exterior scale receptacle.
- NSF-7 compliant for open food product.

**ELECTRICAL**

- Unit completely pre-wired at factory and ready for final connection to a 115/60/1 phase - 15 amp dedicated outlet. Cord and plug set included.



115/60/1  
NEMA-5-15R

**RECOMMENDED OPERATION CONDITIONS**

- TCGG models are designed to operate in an environment where temperature and humidity do not exceed 75°F (23.8°C) and 55% relative humidity.

**OPTIONAL FEATURES/ACCESSORIES**

- Upcharge and lead times may apply.
- 6" (153 mm) standard legs.
  - 6" (153 mm) seismic/flanged legs.
  - 2<sup>1</sup>/<sub>2</sub>" (64 mm) diameter castors.
  - Ratchet locks.
  - Additional lighted shelves.
  - Non-lighted shelves.
  - Lighted stainless steel mezzanine shelves.
  - Non-lighted stainless steel mezzanine shelves.
  - Remote cabinets (condensing unit supplied by others; system comes standard with 404A expansion valve and requires R404A refrigerant). Consult factory technical service department for BTU information.

**PLAN VIEW**

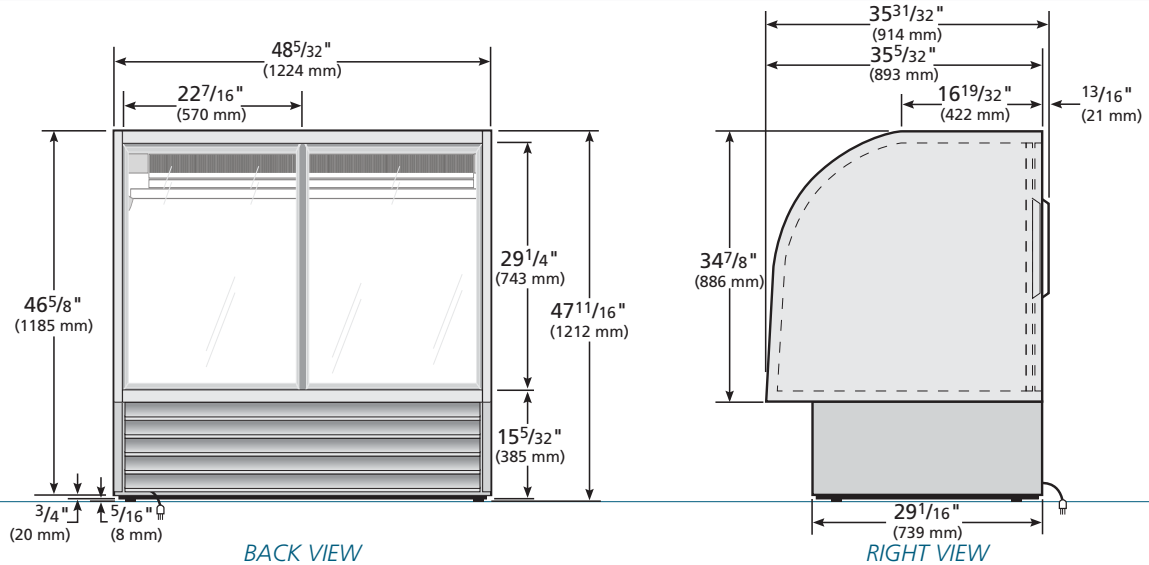

**WARRANTY**  
One year warranty on all parts & labor and an additional 4 year warranty on compressor. (U.S.A. only)

METRIC DIMENSIONS ROUNDED UP TO THE NEAREST WHOLE MILLIMETER  
SPECIFICATIONS SUBJECT TO CHANGE WITHOUT NOTICE



Model	Elevation	Right	Plan	3D	Back
TCGG-48-S	TFD048E	TFD047S	TFD048P	TFD0483	TFD048B

**TRUE FOOD SERVICE EQUIPMENT**