



TRUE FOOD SERVICE EQUIPMENT, INC.

St. Charles Industrial Center • P.O. Box 970 • O'Fallon, Missouri 63366
 (636)240-2400 • FAX (636)272-2408 • (800)325-6152 • www.truemfg.com
 Parts Dept. (800)424-TRUE • Parts Dept. FAX# (636)272-9471

Project Name: _____

Location: _____

Item #: _____ Qty: _____

Model #: _____

A/A #

SIS #

Model:
TCGG-72

Display Case:
Curved Glass Deli Case



TCGG-72

- ▶ True's curved glass deli display case combines efficient, high volume merchandising and exceptional refrigeration with an elegant curved glass front for sophisticated presentation of deli products.
- ▶ Exceptional gravity coil refrigeration system maintains 38°F to 40°F (3.3°C to 4.4°C) for the freshest display of meats and cheeses designed to increase sales and profits.
- ▶ Self-contained, environmentally friendly (CFC free) 134A refrigeration system.
- ▶ Cabinet is NSF-7 certified to hold open food product.
- ▶ Insulated double pane curved front glass provides maximum insulation value for greater efficiency and energy savings. Both panes are tempered for safety.
- ▶ Two (2) adjustable, lighted, cantilevered PVC coated shelves.
- ▶ Fluorescent lamps are low UV emitting to enhance product appearance and increase shelf life.
- ▶ White laminated vinyl exterior. Stainless steel top and trim.
- ▶ White aluminum interior sides and top. 300 series stainless steel floor with coved corners.

ROUGH-IN DATA

Specifications subject to change without notice.
 Chart dimensions rounded up to the nearest 1/8" (millimeters rounded up to next whole number).

Model	Doors	Capacity (Cu. Ft.) (liters)	# of Shelves	Cabinet Dimensions (inches) (mm)			HP	Voltage	Amps	NEMA Config.	Cord Length (total ft.) (total m)	Crated Weight (lbs.) (kg)
				L	D†	H						
TCGG-72	2	37.1 1051	2	72 ¹ / ₄ 1836	35 ¹ / ₄ 896	47 ³ / ₄ 1213	³ / ₄	115/60/1	16.0	5-20P	9 2.74	N/A N/A

† Depth does not include 7/8" (23 mm) for rear door handles.

12/05 Printed in U.S.A.

APPROVALS:

AVAILABLE AT:

Model:
TCGG-72

Display Case:
Curved Glass Deli Case



STANDARD FEATURES

DESIGN

- True's curved glass deli display case combines efficient, high volume merchandising and exceptional refrigeration with an elegant curved glass front for sophisticated presentation of deli products.
- Exceptional gravity coil refrigeration system guarantees the freshest display of meats and cheeses designed to increase sales and profits.

REFRIGERATION SYSTEM

- Factory engineered, self-contained, capillary tube system using environmentally friendly (CFC free) 134A refrigerant.
- Extra large evaporator coil balanced with higher horsepower compressor and large condenser maintains 38°F to 40°F (3.3°C to 4.4°C).
- Gravity coil refrigeration system. Ideally suited for deli meats, cheeses and salads.
- Condensing unit located behind panel in back of unit. Entire system slides out for easy cleaning and maintenance.
- Automatic defrost system; time-initiated, time-terminated.

CABINET CONSTRUCTION

- Exterior - durable and permanent no peel or chip white laminated vinyl with stainless steel top and trim. Black front and rear grills and trim.
- Interior - NSF approved white aluminum sides and top. 300 series stainless steel floor with coved corners.
- Insulation - entire cabinet structure is foamed-in-place using high density, CFC free, polyurethane insulation.

- Welded, heavy duty galvanized frame rail dipped in rust inhibiting enamel paint for corrosion protection inside and out.
- Frame rail fitted with leg levelers.

CURVED FRONT DISPLAY GLASS

- Insulated double pane glass provides maximum insulation value for greater efficiency and energy savings. Both panes are tempered for safety.

DOORS

- "Low-E", double pane thermal glass insert with mitered plastic channel frame.
- Each door fitted with 12" (305 mm) long molded plastic handle.
- Self-closing doors, efficient counter balanced weight system for smooth, even, positive closure. Sliding doors ride on stainless steel V-Channel with stainless steel bearings. Doors fit within plastic channel frame.

SHELVING

- Two (2) adjustable, lighted, white heavy duty PVC coated wire shelves 67³/₄" L x 14³/₁₆" D (1721 mm x 361 mm). Shelving is cantilevered and angle can be adjusted to maximize presentation.

LIGHTING

- Cabinet is equipped with three (3) light sources for maximum product display; two (2) shelf mounted and one (1) cabinet mounted. Fluorescent lamps are low UV emitting to enhance product appearance and increase shelf life.

MODEL FEATURES

- Evaporator is epoxy coated to eliminate the potential of corrosion.
- Four (4) amp exterior scale receptacle.
- NSF-7 compliant for open food product.

ELECTRICAL

- Unit completely pre-wired at factory and ready for final connection to a 115/60/1 phase - 20 amp dedicated outlet. Cord and plug set included.



115/60/1
NEMA-5-20R

RECOMMENDED OPERATION CONDITIONS

- TCGG models are designed to operate in an environment where temperature and humidity do not exceed 75°F (23.8°C) and 55% relative humidity.

OPTIONAL FEATURES/ACCESSORIES

Upcharge and lead times may apply.

- 6" (153 mm) standard legs.
- 6" (153 mm) stainless steel legs.
- 2¹/₂" (64 mm) diameter castors.
- Ratchet locks.
- Additional lighted shelves.
- Non-lighted shelves.
- Lighted stainless steel mezzanine shelves.
- Non-lighted stainless steel mezzanine.
- Remote cabinets (condensing units supplied by others; system comes standard with 404A expansion valve and requires R404A refrigerant). Consult factory technical service department for BTU information.

PLAN VIEW

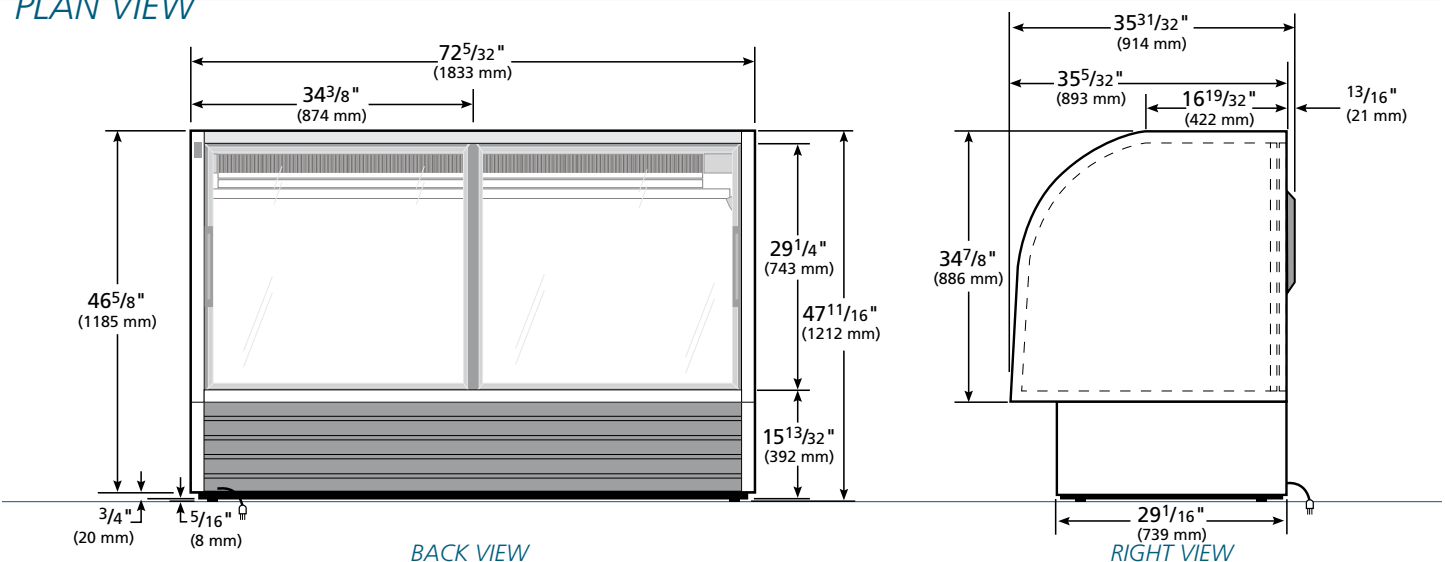

WARRANTY
One year warranty on all parts & labor and an additional 4 year warranty on compressor. (U.S.A. only)

METRIC DIMENSIONS ROUNDED UP TO THE NEAREST WHOLE MILLIMETER
SPECIFICATIONS SUBJECT TO CHANGE WITHOUT NOTICE



Model	Elevation	Right	Plan	3D	Back
TCGG-72	TFD057E	TFD057S	TFD057P	TFD0573	TFD057B

TRUE FOOD SERVICE EQUIPMENT

St. Charles Industrial Center • P.O. Box 970 • O'Fallon, Missouri 63366 • (636)240-2400 • FAX (636)272-2408 • (800)325-6152 • www.truemfg.com